

802.11a White Paper

Table of Contents	Page
1. Glossary	2
2. Introduction to 802.11a.....	3
3. 802.11a Overview.....	4
4. 802.11a OFDM PHY specific service parameter list.....	5
5. OFDM PLCP sublayer of the 802.11a	7
6. Data Scrambler.....	14
7. Convolutional Encoding	15
8. Data Interleaving	16
9. Modulation and Mapping.....	17
10. OFDM Operating Channels and Transmit Power Requirements	18
11. 802.11a System Description.....	19

1. Glossary

This document uses the following abbreviations for 802.11a.

ADSL	Asymmetrical Digital Subscriber Loop
BPSK	Binary Phase Shift Keying
CCA	Clear Channel Assessment
DMT	Discrete Multi Tone
DSSS	Direct Sequence Spread Spectrum
FEC	Forward Error Correction
FFT	Fast Fourier Transform
FHSS	Frequency Hopping Spread Spectrum
GI	Guard Interval
IFFT	Inverse Fast Fourier Transform
LAN	Local Area Network
MAC	Medium Access Control Layer
MIB	Management Information Base
MLME	MAC Layer Management Entity
MPDU	MAC Protocol Data Units
N_{BPSK}	Number of coded bits per subcarrier
N_{CBPS}	Number of coded bits per OFDM symbol
N_{DBPS}	Number of data bits per OFDM symbol
OFDM	Orthogonal Frequency Division Multiplexing
PHY	Physical Layer
PLCP	Physical Layer Convergence Procedure
PLME	Physical Layer Management Entity
PMD	Physical Medium Dependent
PPDU	PLCP Protocol Data Unit
PSDU	PHY Sublayer Service Data Units
QAM	Quadrature Amplitude Modulation
QPSK	Quadrature Phase Shift Keying
SAP	Service Access Point
WLAN	Wireless Local Area Network

2. Introduction to 802.11a

IEEE 802.11 standard specifies a 2.4 GHz operating frequency with data rates of 1 and 2 Mbps using either Direct Sequence Spread Spectrum (DSSS) or Frequency Hopping Spread Spectrum (FHSS). The IEEE 802.11a standard specifies an OFDM physical layer (PHY) that splits an information signal across 52 separate subcarriers to provide transmission of data at a rate of 6, 9, 12, 18, 24, 36, 48, or 54 Mbps. In the 802.11a IEEE standard the 6, 12, and 24 Mbps data rates are mandatory. Four of the subcarriers are pilot subcarriers that the system uses as a reference to disregard frequency or phase shifts of the signal during transmission.

In the 802.11a standard, a pseudo binary sequence is sent through the pilot subchannels to prevent the generation of spectral lines. In the 802.11a, the remaining 48 subcarriers provide separate wireless pathways for sending the information in a parallel fashion. The resulting subcarrier frequency spacing in the IEEE 802.11a standard is 0.3125 MHz (for a 20 MHz with 64 possible subcarrier frequency slots).

802.11a standard, the primary purpose of the OFDM PHY is to transmit Media Access Control (MAC) Protocol Data Units (MPDUs) as directed by the 802.11 MAC layer. The OFDM PHY of the 802.11a standard is divided into two elements: the Physical Layer Convergence Protocol (PLCP) and the Physical Medium Dependent (PMD) sublayers.

The MAC layer of 802.11a standard communicates with the PLCP via specific primitives through a PHY service access point. When the MAC layer instructs, the PLCP prepares MPDUs for transmission. The PLCP also delivers incoming frames from the wireless medium to the MAC layer. The PLCP sublayer minimizes the dependence of the MAC layer on the PMD sublayer by mapping MPDUs into a frame format suitable for transmission by the PMD.

Under the direction of the PLCP, the PMD provides actual transmission and reception of PHY entities between two stations through the wireless medium. To provide this service, the PMD interfaces directly with the air medium and provides modulation and demodulation of the frame transmissions. The PLCP and PMD communicate using service primitives to govern the transmission and reception functions.

With 802.11a OFDM modulation, the binary serial signal is divided into groups (symbols) of one, two, four, or six bits, depending on the data rate chosen, and converted into complex numbers representing applicable constellation points. If a data rate of 24 Mbps is chosen, for example, then the PLCP maps the data bits to a 16QAM constellation.

After mapping, the PLCP normalizes the complex numbers in the 802.11a standard to achieve the same average power for all mappings. The PLCP assigns each symbol, having duration of 4 microseconds, to a particular subcarrier. An Inverse Fast Fourier transform (IFFT) combines the subcarriers before transmission.

As with other 802.11 based PHYs, in the 802.11a the PLCP implements a clear channel assessment protocol by reporting a medium busy or clear to the MAC layer via a primitive through the service access point. The MAC layer uses this information to determine whether to issue instructions to actually transmit an MPDU.

The 802.11a standard requires receivers to have a minimum sensitivity ranging from -82 to -65 dBm, depending on the chosen data rate.

3. 802.11a Overview

The IEEE 802.11a is an Orthogonal Frequency Division Multiplexing (OFDM) system very similar to Asymmetrical Digital Subscriber Loop (ADSL) Discrete Multi Tone (DMT) modems sending several subcarriers in parallel using the Inverse Fast Fourier Transform (IFFT), and receiving those subcarriers using the Fast Fourier Transform (FFT).

In 802.11a the transmission medium is wireless and the operating frequency band is 5 GHz.

The OFDM of the 802.11a system provides a Wireless LAN with data payload communication capabilities of 6, 9, 12, 18, 24, 36, 48 and 54 Mbps. The support of transmitting and receiving at data rates of 6, 12, and 24 Mbps is mandatory in the standard. The 802.11a system uses 52 subcarriers that are modulated using binary or quadrature phase shift keying (BPSK/QPSK), 16 Quadrature Amplitude Modulation (QAM), or 64 QAM. Forward Error Correction (FEC) coding (convolutional coding) is used with a coding rate of 1/2, 2/3, or 3/4.

The OFDM PHY layer consists of two protocol functions: first a PHY convergence function, which adapts the capabilities of the Physical Medium Dependent (PMD) system to the PHY service. This function is supported by the Physical Layer Convergence Procedure (PLCP), which defines a method of mapping the IEEE 802.11 PHY Sublayer Service Data Units (PSDU) into a framing format suitable for sending and receiving user data and management information between two or more stations using the associated PMD system. Second a PMD system whose function defines the characteristics and method of transmitting and receiving data through a wireless medium between two or more stations, each using the OFDM system.

4. 802.11a OFDM PHY specific service parameter list

The architecture of the IEEE 802.11 MAC is intended to be PHY independent, so different modulation types can use the same MAC. Some PHY implementations require medium management state machines running in the MAC sublayer in order to meet certain PMD requirements. The PHY-dependent MAC state machines reside in a sublayer defined as the MAC sublayer Management Entity (MLME). In certain PMD implementations, the MLME may need to interact with the PLME as part of the normal PHY Service Access Point (SAP) primitives. These interactions are defined by the PLME parameter list currently defined in the PHY service primitives as TXVECTOR and RXVECTOR. The list of these parameters of the 802.11a standard, and the values they may represent, are defined in the specific PHY specifications for each Physical Medium Dependent (PMD).

Table 1 presents the parameters for the 802.11a transmitter, and table 2 presents the parameters for the 802.11a receiver.

Table 1. TXVECTOR parameters for 802.11a

Parameter	Associate primitive	Value
LENGTH	PHY-TXSTART.request (TXVECTOR)	1–4095
DATARATE	PHY-TXSTART.request (TXVECTOR)	6, 9, 12, 18, 24, 36, 48 and 54
SERVICE	PHY-TXSTART.request (TXVECTOR)	Scrambler initialization; 7 null bits + 9 reserved null bits
TXPWR_LEVEL	PHY-TXSTART.request (TXVECTOR)	1–8

The TXVECTOR_LENGTH is used in the 802.11a to indicate the number of octets in the MPDU, which the MAC is currently requesting the PHY to transmit. The PHY uses this value to determine the number of octet transfers that will occur between the MAC and the PHY after receiving a request to start the transmission.

The TXVECTOR_DATARATE of the 802.11a describes the bit rate at which the PLCP transmits the PSDU.

The TXVECTOR_SERVICE of the 802.11a is 7 null bits used for the scrambler initialization and 9 null bits reserved for future use.

The TXVECTOR_TXPWR_LEVEL of the 802.11a is used to indicate which of the available TxPowerLevel attributes defined in the MIB are used for the current transmission.

Table 2. RXVECTOR parameters of the 802.11a

Parameter	Associate primitive	Value
LENGTH	PHY-RXSTART.indicate	1–4095
RSSI	PHY-RXSTART.indicate (RXVECTOR)	0–RSSI maximum
DATARATE	PHY-RXSTART.request (RXVECTOR)	6, 9, 12, 18, 24, 36, 48 and 54
SERVICE	PHY-RXSTART.request (RXVECTOR)	Null

The RXVECTOR_LENGTH of the 802.11a is used to indicate the value contained in the LENGTH field, which the PLCP has received in the PLCP header. The MAC and PLCP will use this value to determine the number of octet transfers that will occur between the two sublayers during the transfer of the received PSDU.

The RXVECTOR_RSSI of the 802.11a is a measure by the PHY sublayer of the energy observed at the antenna used to receive the current PPDU. RSSI is measured during the reception of the PLCP preamble

The RXVECTOR_DATARATE of the 802.11a represents the data rate at which the current PPDU was received.

The RXVECTOR_SERVICE of the 802.11a is a null field.

5. OFDM PLCP sublayer of the 802.11a

The PHY Sublayer Service Data Units (PSDU) of the 802.11a is converted to a PLCP Protocol Data Unit (PPDU). The PSDU of the 802.11a is provided with a PLCP preamble and header to create the PPDU. At the receiver of the 802.11a, the PLCP preamble and header are processed to aid in demodulation and delivery of the PSDU.

The PPDU is unique to the OFDM PHY. The PPDU format of the standard 802.11a is shown in figure 1 and it includes:

- **PLCP preamble.** This field is used to acquire the incoming OFDM signal and train and synchronize the demodulator. The PLCP preamble consists of 12 symbols, 10 of which are short symbols and 2 long symbols. The short symbols are used to train the receiver's AGC and to estimate a coarse estimate of the carrier frequency and the channel. The long symbols are used to fine-tune the frequency and the channel estimates. Twelve subcarriers are used for the short symbols and 53 for the long. The training of an OFDM is accomplished in 16 μ s. The PLCP preamble is BPSK-OFDM modulated at 6 Mbps using convolutional encoding rate $R=1/2$.
- **SIGNAL.** This is a 24 bits field, which contains information about the rate and length of the PSDU. The PLCP preamble is BPSK-OFDM modulated at 6 Mbps using convolutional encoding rate $R=1/2$. The first 4 bits (R1-R4) are used to encode the rate. The next bit is 1 reserved bit. A continuation they are 12 bits used for the length, that indicated the number of octets in the PSDU. A continuation is a parity bit and 6 tail bits.
- **DATA.** This field contains 16 bits for the service field, the PSDU, tails bits and pad bits. A total of 6 tail bits containing 0s are appended to the PPDU to ensure that the convolutional encoder is brought back to zero state. The data portion of the packet is transmitted at the data rate indicated in the signal field.

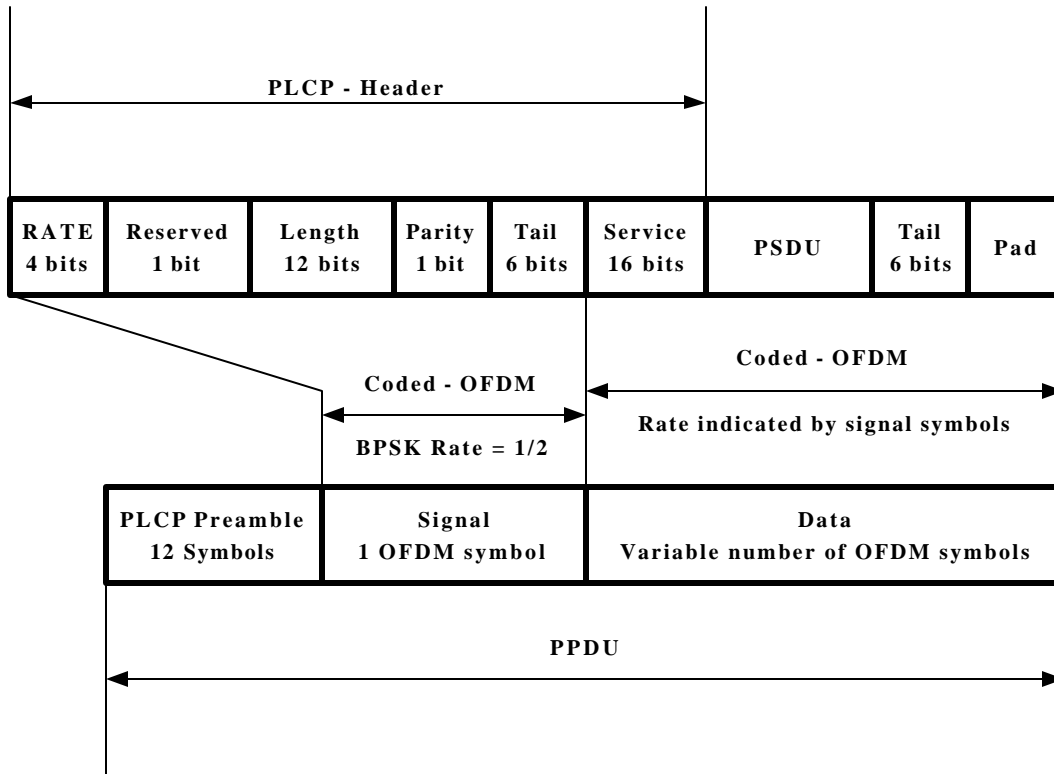

Figure 1. OFDM PLCP Preamble , Header and PSDU of 802.11a

The PLCP header of 802.11a contains:

- 4 bits for the rate
- 1 reserved bit
- 12 bits for length
- 1 bit for parity
- 6 bits for tail
- 16 bits for service

The bits Data Rate bits (RATE) R1-R4 is set, dependent on RATE, according to the values in Table 3.

Table 3 Contents of the SIGNAL field of 802.11a

Rate (Mbps)	R1-R4
6	1101
9	1111
12	0101
18	0111
24	1001
36	1011
48	0001
54	0011

The number of bits in the DATA field in the 802.11a is a multiple of N_{CBPS} , the number of coded bits in an OFDM symbol (48, 96, 192, or 288 bits). To achieve that, the length of the message is extended so that it becomes a multiple of N_{DBPS} , the number of data bits per OFDM symbol. At least 6 bits are appended to the message, in order to accommodate the TAIL bits. The number of OFDM symbols in the 802.11a, N_{SYM} ; the number of bits in the DATA field in the 802.11a, N_{DATA} ; and the number of pad bits in the 802.1a, N_{PAD} , are computed from the length of the PSDU (LENGTH) as follows:

$$N_{SYM} = \left\lceil \frac{16 + 8 * LENGTH + 6}{N_{DBPS}} \right\rceil$$

$$N_{DATA} = N_{SYM} * N_{DBPS}$$

$$N_{PAD} = N_{DATA} - (16 + 8 * LENGTH + 6)$$

Rate, reserved bit, length, parity bit and 6 "zero" tail bits appended constitute a separate single OFDM symbol, denoted signal, which is transmitted in BPSK with a coding rate of $R = 1/2$. The service field of the PLCP header and the PSDU (with 6 "zero" tail bits and pad bits appended), are transmitted at the data rate described in the rate field and constitute a multiple of OFDM symbols. The tail bits in the signal symbol enable decoding of the rate and length fields immediately after the reception of the tail bits. The rate and length are required for decoding the data part of the packet, in addition, the Clear Channel Assessment (CCA) mechanism is used to predict the duration of the packet from the contents of the rate and length fields.

The encoding process is as follows:

1. The PLCP preamble field is produced, composed of 10 repetitions of a "short training sequence" (used for AGC convergence, diversity selection, timing acquisition, and coarse frequency acquisition in the receiver) and two repetitions of a "long training sequence" (used for channel estimation and fine frequency acquisition in the receiver), preceded by a guard interval (GI).
2. The PLCP header field is produced from the RATE, LENGTH, and SERVICE fields of the TXVECTOR by filling the appropriate bit fields. The RATE and LENGTH fields of the PLCP header are encoded by a convolutional code at a rate of $R = 1/2$, and are subsequently mapped onto a single BPSK encoded OFDM symbol, denoted as the SIGNAL symbol. 6 "zero" TAIL bits are inserted into the PLCP header in order to facilitate a reliable and timely detection of the RATE and LENGTH fields. The encoding of the SIGNAL field into an OFDM symbol follows the same steps for convolutional encoding, interleaving, BPSK modulation, pilot insertion, IFFT, and pre-pending a GI (equivalent to the prefix in a ADSL system) as described subsequently for data transmission at 6 Mbps. The contents of the SIGNAL field are not scrambled.
3. Calculate from RATE field of the TXVECTOR the number of data bits per OFDM symbol (N_{DBPS}), the coding rate (R), the number of bits in each OFDM subcarrier (N_{BPSK}), and the number of coded bits per OFDM symbol (N_{CBPS}).
4. When this data rate is calculated, the PSDU is appended to the SERVICE field of the TXVECTOR. Extend the resulting bit string with "zero" bits (at least 6 bits) so that the resulting length will be a multiple of N_{DBPS} . The resulting bit string constitutes the DATA part of the packet.
5. The scrambler is initialized with a pseudorandom non-zero seed, generate a scrambling sequence, and XOR it with the extended string of data bits.
6. Replace the six scrambled "zero" bits following the "data" with six non-scrambled "zero" bits. (Those bits return the convolutional encoder to the "zero state" and are denoted as "tail bits.").
7. Encode the extended, scrambled data string with a convolutional encoder ($R = 1/2$). Omit (puncture) some of the encoder output string (chosen according to "puncturing pattern") to reach the desired "coding rate."
8. Divide the encoded bit string into groups of N_{CBPS} bits. Within each group, perform an "interleaving" (reordering) of the bits according to a rule corresponding to the desired RATE.
9. Divide the resulting coded and interleaved data string into groups of N_{CBPS} bits. For each of the bit groups, convert the bit group into a complex number according to the modulation encoding tables.
10. Divide the complex number string into groups of 48 complex numbers. Each such group will be associated with one OFDM symbol. In each group, the complex numbers will be numbered 0 to 47 and mapped hereafter into OFDM subcarriers numbered -26 to -22, -20 to -8, -6 to -1, 1 to 6, 8 to 20, and 22 to 26. The subcarriers -21, -7, 7, and 21 are skipped and, subsequently, used for inserting pilot subcarriers. The "0" subcarrier, associated with center frequency, is omitted and filled with zero value.
11. Four subcarriers are inserted as pilots into positions -21, -7, 7, and 21. The total number of the subcarriers is 52 ($48 + 4$).
12. For each group of subcarriers -26 to 26, convert the subcarriers to time domain using inverse Fast Fourier Transform. Pre-pending to the IFFT waveform a circular extension of itself thus forming a GI, and truncate the resulting periodic waveform to a single OFDM symbol length by applying time domain windowing.
13. Append the OFDM symbols one after another, starting after the SIGNAL symbol describing the RATE and LENGTH.

14. Up-convert the resulting "complex baseband" waveform to an RF frequency according to the center frequency of the desired channel and transmit.

The modulation parameters dependent on the data rate used is set according to Table 4.

Table 4 Rate-dependent parameters of 802.11a

Data rate (Mbps)	Modulation	Coding rate (R)	Coded bits per subcarrier (N_{BPSC})	Coded bits per OFDM symbol (N_{CBPS})	Data bits per OFDM symbol (N_{DBPS})
6	BPSK	1/2	1	48	24
9	BPSK	3/4	1	48	36
12	QPSK	1/2	2	96	48
18	QPSK	3/4	2	96	72
24	16 QAM	1/2	4	192	96
36	16 QAM	3/4	4	192	144
48	64 QAM	2/3	6	288	192
54	64 QAM	3/4	6	288	216

Table 5 is the list of timing parameters associated with the 802.11a OFDM PLCP.

Table 5 Timing-related parameters of 802.11a

Parameter	Value
N_{SD} : Number of data subcarriers	48
N_{SP} : Number of pilot subcarriers	4
N_{ST} : Number of subcarriers, total	52 ($N_{SD} + N_{SP}$)
ΔF : Subcarrier frequency spacing	0.3125 MHz (=20 MHz/64)
T_{FFT} : IFFT/FFT period	3.2 μ s ($1/\Delta F$)
$T_{PREAMBLE}$: PLCP preamble duration	16 μ s ($T_{SHORT} + T_{LONG}$)
T_{SIGNAL} : Duration of the SIGNAL BPSK-OFDM symbol	4.0 μ s ($T_{GI} + T_{FFT}$)
T_{GI} : GI duration	0.8 μ s ($T_{FFT} / 4$)
T_{GI2} : Training symbol GI duration	1.6 μ s ($T_{FFT} / 2$)
T_{SYM} : Symbol interval	4 μ s ($T_{GI} + T_{FFT}$)
T_{SHORT} : Short training sequence duration	8 μ s ($10 \times T_{FFT} / 4$)
T_{LONG} : Long training sequence duration	8 μ s ($T_{GI2} + 2 \times T_{FFT}$)

A short OFDM training symbol consists of 12 subcarriers, which are modulated by the elements of the sequence S , given by:

$$S_{[-26, 26]} = \sqrt{\frac{13}{6}} \times \{0, 0, 1+j, 0, 0, 0, -1-j, 0, 0, 0, 1+j, 0, 0, 0, -1-j, 0, 0, 0, -1-j, 0, 0, 0, 1+j, 0, 0, 0, 0, 0, 0, 0, 0, -1-j, 0, 0, 0, -1-j, 0, 0, 0, 1+j, 0, 0, 0, 1+j, 0, 0, 0, 1+j, 0, 0, 0, 1+j, 0, 0\}$$

The multiplication by a factor of $\sqrt{\frac{13}{6}}$ is in order to normalize the average power of the resulting OFDM symbol, which utilizes 12 out of 52 subcarriers.

A long OFDM training symbol consists of 53 subcarriers (including a zero value at DC), which are modulated by the elements of the sequence L , given by:

$$L_{[-26, 26]} = \{1, 1, -1, -1, 1, 1, -1, 1, -1, 1, 1, 1, 1, 1, 1, -1, -1, 1, 1, -1, 1, -1, 1, 1, 1, 1, 0, 1, -1, -1, 1, 1, -1, 1, -1, 1, -1, -1, -1, -1, -1, 1, 1, -1, -1, 1, -1, 1, -1, 1, 1, 1\}$$

6. Data Scrambler

All the bits transmitted by the 802.11a OFDM PMD in the data portion are scrambled using a frame synchronous 127 bits sequence generator. Scrambling is used to randomize the service, PSDU, pad and data patterns, which may contain long strings of binary 1s or 0s. The tail bits are not scrambled. The octets of the PSDU are placed in the transmitted serial bit stream, bit 0 first and bit 7 last. The frame synchronous scrambler uses the generator polynomial $S(x)$ as follows:

$$S(x) = x^7 + x^4 + 1$$

The 127bit sequence generated repeatedly by the scrambler is (leftmost used first), 00001110 11110010 11001001 00000010 00100110 00101110 10110110 00001100 11010100 11100111 10110100 00101010 11111010 01010001 10111000 11111111, when the "all ones" initial state is used. The same scrambler is used to scramble transmit data and to de-scramble receive data. When transmitting, the initial state of the 802.11a scrambler will be set to a pseudo random non-zero state. The seven LSBs of the SERVICE field will be set to all zeros prior to scrambling to enable estimation of the initial state of the scrambler in the receiver. The contents of the SIGNAL field of the 802.11a are not scrambled.

The PLCP length field of the 802.11a is an unsigned 12 bits integer that indicates the number of octets in the PSDU that the MAC is currently requesting the PHY to transmit. This value is used by the PHY to determine the number of octet transfers that will occur between the MAC and the PHY after receiving a request to start transmission. The transmitted value is determined from the LENGTH parameter in the TXVECTOR issued with the PHY-TXSTART.request primitive. The LSB is transmitted first in time. The PLCP length field is encoded by the convolutional encoder.

Bit 4 reserved for future use. Bit 17 is a positive parity (even parity) bit for bits 0-16. The bits 18-23 constitute the SIGNAL TAIL field, and all 6 bits is set to zero.

The DATA field contains the SERVICE field, the PSDU, the TAIL bits, and the PAD bits, if needed. All bits in the DATA field are scrambled.

The IEEE 802.11 SERVICE field has 16 bits, which is denoted as bits 0-15. The bit 0 is transmitted first in time. The bits from 0-6 of the SERVICE field, which are transmitted first, are set to zeros and are used to synchronize the descrambler in the receiver. The remaining 9 bits (7-15) of the SERVICE field is reserved for future use. All reserved bits is set to zero.

7. Convolutional Encoding

The PPDU tail bit field is six bits of "0", which are required to return the convolutional encoder to the "zero state." This procedure improves the error probability of the convolutional decoder, which relies on future bits when decoding and which may be not be available past the end of the message. The PLCP tail bit field is produced by replacing six scrambled "zero" bits following the message end with six non-scrambled "zero" bits.

The appended bits ("pad bits") are set to "zeros" and are subsequently scrambled with the rest of the bits in the DATA field.

The DATA field of the 802.11a, composed of SERVICE, PSDU, tail, and pad parts, is coded with a convolutional encoder of coding rate $R = 1/2, 2/3, \text{ or } 3/4$, corresponding to the desired data rate. The convolutional encoder used the generator polynomials, $g_0 = (133)_o$ and $g_1 = (171)_o$, of rate $R = 1/2$. Higher rates are derived from it by employing "puncturing" Puncturing is a procedure for omitting some of the encoded bits in the transmitter (thus reducing the number of transmitted bits and increasing the coding rate) and inserting a dummy "zero" metric into the convolutional decoder on the receive side in place of the omitted bits.

8. Data Interleaving

In the 802.11a standard, a block interleaver interleaves all encoded data bits. The block size corresponds to the number of bits in a single OFDM symbol, N_{CBPS} . The interleaver is defined by a two steps permutation. The first permutation ensures that adjacent coded bits are mapped onto nonadjacent subcarriers. The second ensures that adjacent coded bits are mapped alternately onto less and more significant bits of the constellation and, thereby, long runs of low reliability (LSB) bits are avoided.

9. Modulation and Mapping

The OFDM subcarriers are modulated by using BPSK, QPSK, 16 QAM, or 64 QAM modulation, depending on the RATE requested. In the 802.11a the encoded and interleaved binary serial input data are divided into groups of N_{BPSC} (1, 2, 4, or 6) bits and converted into complex numbers representing BPSK, QPSK, 16 QAM, or 64 QAM constellation points. The conversion is performed according to Gray coded constellation mappings.

In each OFDM symbol, four of the subcarriers are dedicated to pilot signals in order to make the coherent detection robust against frequency offsets and phase noise. These pilot signals are in subcarriers -21, -7, 7 and 21. The pilots are BPSK modulated by a pseudo binary sequence to prevent the generation of spectral lines.

The stream of complex numbers is divided into groups of $N_{\text{SD}} = 48$ complex numbers. The complex number $d_{(k,n)}$, corresponds to subcarrier k of OFDM symbol n , is:

$$d_{(k,n)} = d_{(k+N_{\text{SD}},n)} \quad k = 0, \dots, N_{\text{SD}} - 1; \quad n = 0, \dots, N_{\text{SYM}} - 1$$

PLCP provides the capability to perform CCA and report the result to the MAC. The CCA mechanism detects a "medium busy" condition. The primitive PHY_CCA.indicate indicates the medium status report.

The PLCP preamble of the 802.11a is transmitted using an OFDM modulated fixed waveform. The 802.11 SIGNAL field, BPSK OFDM modulated at 6 Mbps, indicates the modulation and coding rate that is used to transmit the MPDU. The transmitter (receiver) initiates the modulation (demodulation) constellation and the coding rate according to the RATE indicated in the SIGNAL field. The MPDU transmission rate is set by the DATARATE parameter in the TXVECTOR, issued with the PHY-TXSTART.

10. OFDM Operating Channels and Transmit Power Requirements

For the 802.11a standard the 5 GHz U-NII frequency band is segmented into three 100 MHz bands for operation in the US. The lower band ranges from 5.15 –5.25 GHz, the middle band ranges from 5.25-5.35 GHz and the upper band ranges from 5.725-5.825 GHz. The lower and middle band, accommodate 8 channels in a total bandwidth of 200 MHz and the upper band accommodates 4 channels in a 100 MHz bandwidth. The frequency channel center frequencies are spaced 20 MHz apart. The outermost channels of the lower and middle bands are centered 30 MHz from the outer edges. In the upper band the outermost channel centers are 20 MHz from the outer edges.

In addition to the frequency and channel allocations, transmit power is a key parameter regulated in the 5 GHz U-NII band. Three transmit power levels are specified: 40 mW, 200 mW and 800 mW. The upper band defines RF transmit power levels suitable for bridging applications while the lower band specifies a transmit power level suitable for short-range indoor home and small office environments.

Table 6 shows the operating frequency and maximum power of the 802.11a standard.

Table 6. OFDM Operating Bands and channels

Band	Channel numbers	Frequency (MHz)	Maximum output power
U-NII lower band 5.15 to 5.25 MHz	36	5180	40mW (2.5mW/MHz)
	40	5200	
	44	5220	
	48	5240	
U-NII lower band 5.25 to 5.35 MHz	52	5260	200mW (12.5mW/MHz)
	56	5280	
	60	5300	
	64	5320	
U-NII upper band 5.725 to 5.825 MHz	149	5745	800mW (50mW/MHz)
	153	5765	
	157	5785	
	161	5805	

11. 802.11a System Description

Figure 2 shows a block diagram of the transmitter.

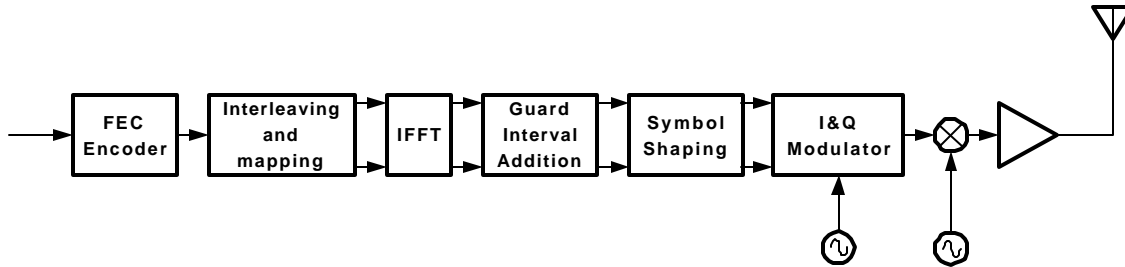

Figure 2. 802.11a Transmitter Block Diagram

Figure 3 shows a block diagram of the receiver.

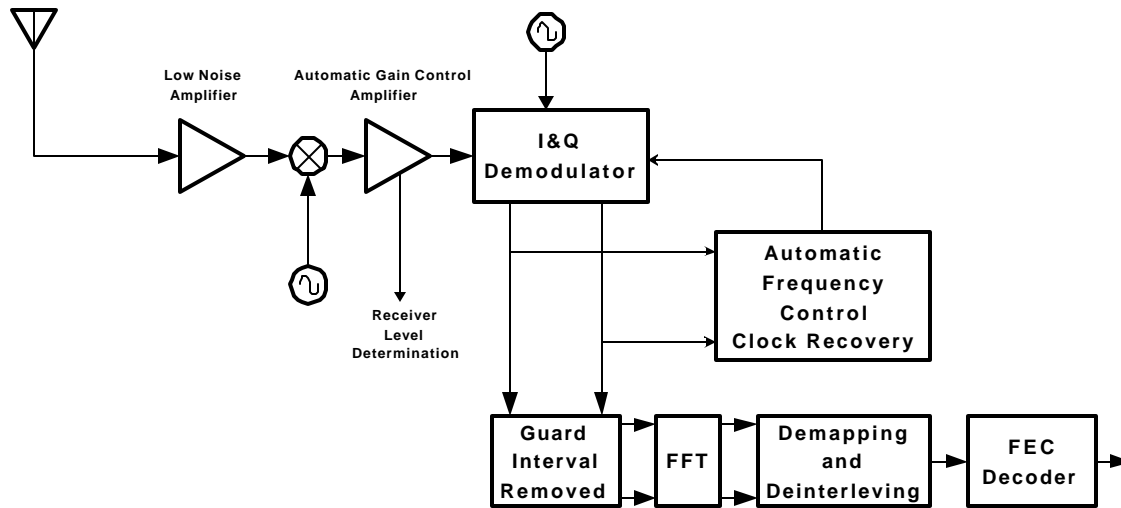

Figure 3. 802.11a Receiver Block Diagram